

AGM START-STOP BATTERY

AGM-B24R (12V45Ah)



CHARACTERISTICS

| Item | Specifications | |
|--------------------------------|------------------------------|--------------------|
| Nominal Voltage | 12V | |
| Nominal Capacity (20HR) | 45Ah | |
| Reserve Capacity | 70min | |
| Cold Cranking Amps@0°F (-18°C) | 380A | |
| Dimension | Length | 236mm (9.29inches) |
| | Width | 128mm (5.04inches) |
| | Container Height | 202mm (7.95inches) |
| | Total Height (with Terminal) | 222mm (8.74inches) |
| Approx Weight | 13.6kg (30.0lbs) | |
| Terminal | 3 | |
| Cell layout | 1 | |
| Hold-Down | B0 | |
| Case | Black-PP Material | |
| Cover | Black-PP Material | |
| Handle | TS1 | |

APPLICATIONS

- Car with start-stop system
- EV/HEV
- Engine start

GENERAL FEATURES

- Maximum CCA and life
- Valve regulated technology
- Advanced Absorbed Glass Mat (AGM) technology
- Top-level safety - absolutely no free acid
- 2x Faster Charge Acceptance than conventional starter batteries
- 3x higher cycle life than conventional starter batteries
- Suit for working in partial state of charge operations (PSoC)
- OE quality certification

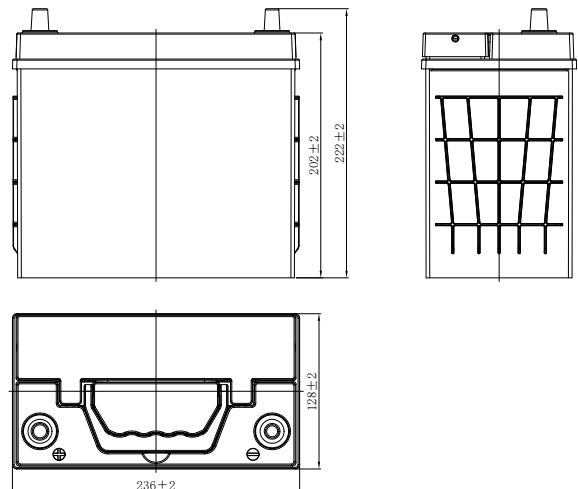
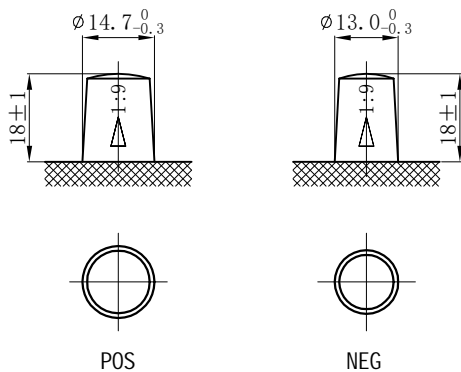

*Values are subject to variation of +/- 5% in normal manufacturing processes.