

# EV12-200

12V 200Ah(10hr)

The rechargeable batteries are lead-lead dioxide systems. The dilute sulfuric acid electrolyte is absorbed by separators and plates and thus immobilized. Should the battery be accidentally overcharged producing hydrogen and oxygen, special one-way valves allow the gases to escape thus avoiding excessive pressure build-up. Otherwise, the battery is completely sealed and is, therefore, maintenance-free, leak proof and usable in any position.

## Battery Construction

Component	Positive plate	Negative plate	Container	Cover	Safety valve	Terminal	Separator	Electrolyte
Raw material	Lead dioxide	Lead	ABS	ABS	Rubber	Copper	Fiberglass	Sulfuric acid

## General Features

- Absorbent Glass Mat (AGM) technology for efficient gas recombination of up to 99% and freedom from electrolyte maintenance or water adding.
- Not restricted for air transport-complies with IATA/ICAO Special Provision A67.
- UL-recognized component.
- Can be mounted in any orientation.
- Computer designed lead, calcium tin alloy grid for high power density.
- Long service life, float or cyclic applications.
- Maintenance-free operation.
- Low self discharge.

## Dimensions and Weight

Length(mm / inch)	522/20.55
Width(mm / inch)	238/9.37
Height(mm / inch)	218/8.58
Total Height(mm / inch)	223/8.78
Approx. Weight(Kg / lbs)	60/132.28

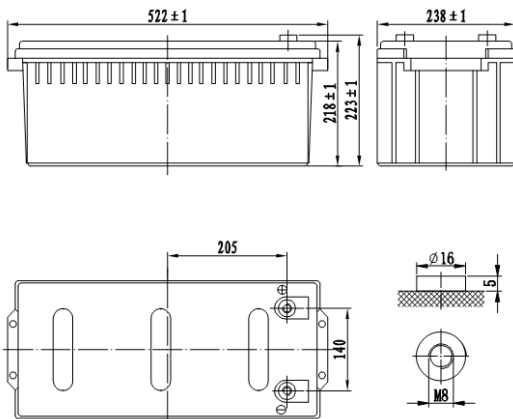

## Performance Characteristics

Nominal Voltage	12V
Number of cell	6
Design Life	10 years
Nominal Capacity 77°F(25°C)	
10 hour rate (20.0A, 10.8V)	200Ah
5 hour rate (33.66A, 10.8V)	168.3Ah
1 hour rate (118.6A, 10.5V)	118.6Ah
Internal Resistance	
Fully Charged battery 77°F(25°C)	≤ 4.0mOhms
Self-Discharge	
3% of capacity declined per month at 25 °C (average)	
Operating Temperature Range	
Discharge	-20~60°C
Charge	-10~55°C
Storage	-10~50°C
Max. Discharge Current 77°F(25°C)	2000A(5s)
Short Circuit Current	3500A
Charge Methods: Constant Voltage Charge 77°F(25 °C )	
Cycle use	2.40-2.45VPC
Maximum charging current	60A
Temperature compensation	-30mV/°C
Standby use	2.20-2.30VPC
Temperature compensation	-20mV/°C

## Discharge Constant Current (Amperes at 77 °F25 °C)

End Point Volts/Cell	10min	15min	30min	1h	3h	5h	8h	10h	20h
1.60V	409.4	322.6	187.1	118.6	54.55	36.73	25.05	21.50	10.85
1.65V	395.8	313.0	183.1	116.3	53.76	36.34	24.85	21.30	10.75
1.70V	377.9	300.3	177.9	113.4	52.67	35.74	24.46	21.00	10.65
1.75V	354.1	283.3	170.9	109.3	51.09	34.85	23.96	20.60	10.45
1.80V	322.3	260.4	161.2	103.8	49.01	33.66	23.17	20.00	10.25

## Discharge Constant Power (Watts at 77 ° F25 °C)

End Point Volts/Cell	10min	15min	30min	1h	2h	3h	5h	8h	10h
1.60V	696	564	340	221.8	138.6	104.0	70.9	49.0	42.2
1.65V	690	559	337	219.8	137.6	103.0	70.3	48.6	41.9
1.70V	667	541	329	214.9	134.7	101.0	69.3	47.9	41.3
1.75V	636	518	320	207.9	130.7	98.9	67.9	47.0	40.6
1.80V	589	482	305	199.0	125.7	95.1	65.8	45.7	39.5

(Note)The above characteristics data are average values obtained within three charge/discharge cycles not the minimum values.

# EV12-200

12V 200Ah(10hr)

**Discharge characteristic (25°C)**

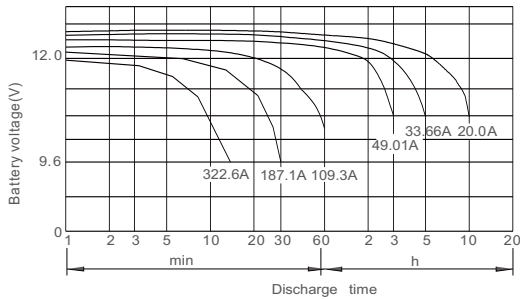

**Constant voltage charging characteristic (0.25CA, 25°C)**

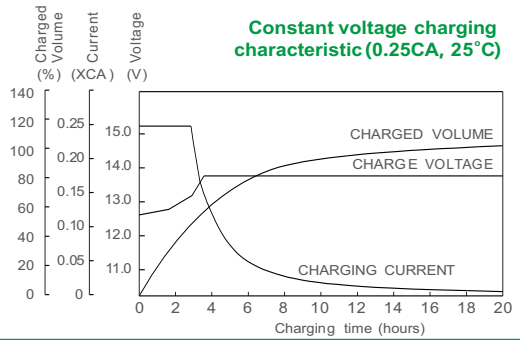

**Relationship between charging voltage and temperature**

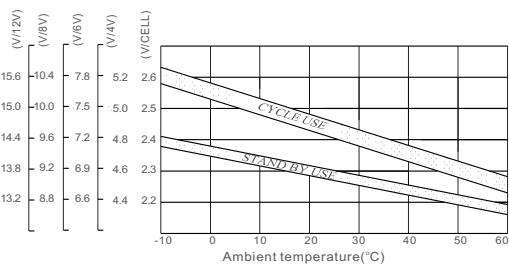

**Self-discharge characteristic**

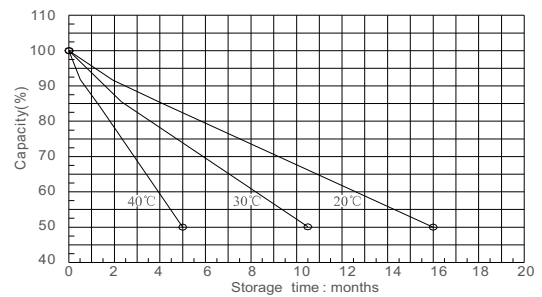

**Life characteristics of Standby use**

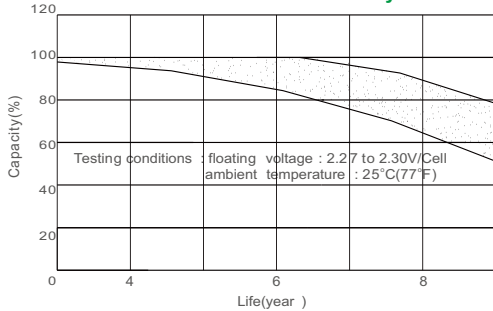

**Cycle service life in relation to depth of discharge**

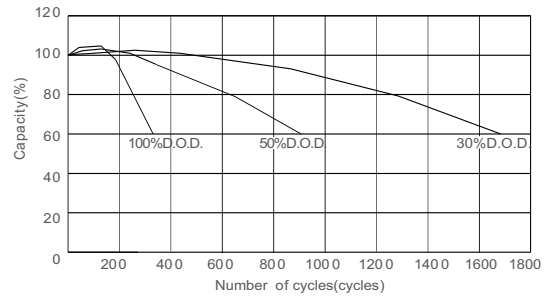

**Temperature effects on float life**

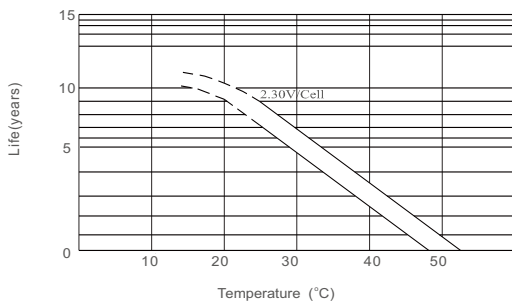

**Temperature effects on capacity**

