

Specification for Battery charger

Model: S120

14.6V / 4A

LiFePO4 Battery Charger



Contents

1. General	3
2. Main product specification.....	3
3. Environmental condition	3
4. Electrical characteristics	3
4.1 Input Characteristics.....	3
4.2 Output characteristic or charge stages	3
4.3 Protection characteristics.....	4
4.4 Charging indicator	4
5. Safety & EMC.....	5
6. Environmental testing requirements	5
7. Mechanical characteristic:.....	6
8. Package, transportation & storage.....	6
8.1 Package.....	6
8.2 Transportation.....	6
8.3 Storage	7
9. Reliability requirements	7
10. Charging curve.....	7

1. General

Battery Charger 360A 180×90×63mm can work normally under 14.6Vdc/20A and with reverse polarity protection.

2. Main product specification

Max. output power	Input voltage	Output voltage	Combined regulation	Output current	Combined regulation
58.4W	180-240Vac	14.6V±0.2Vdc	±0.2V	4A	±0.2V

3. Environmental condition

Parameter	Technical Specification	Remark
Humidity	5 – 95%	With package
Altitude	≤3000m	Work normally

4. Electrical characteristics

4.1 Input Characteristics

Parameter	Technical specification	Remark
Rated input voltage	180 – 240Vac	230Vac
Input voltage range	180 – 240Vac	
AC input voltage frequency	50 – 60 Hz	

4.2 Output characteristic or charge stages

Parameter	Technical Specification	Remark
CC (Constant Current)	≤14.6Vdc, 4A	
CV (Constant Voltage)	14.6Vdc, 4A↓	
Float stage	none	
Power efficiency	≥90%	Vin = 230Vac, rated load

4.3 Protection characteristics

Parameter	Technical Specification	Remark
Over voltage protection	Yes	
Software over voltage protection	The charger software limits the maximum output voltage to a level suitable for the connected battery system.	
Thermal protection	Yes	
Current limiting protection	Yes	At CC mode
Short circuit protection	Short circuit protection should be automatically recovery after remove the condition.	
Reverse polarity protection	When output wires are reversely connected to the battery the charger will not operate and will work normally when DC wires are correctly connected.	Optional

4.4 Charging indicator

Parameter	Status	Remark
Power ON	LED1: Red	
Charging	LED2: Red	
Fully charged	LED2: Green	
Charging voltage display	No	
Charging current display	No	

5. Safety & EMC

Item		Standard (or test condition)	Remark
Electric strength test	Input – output	1500Vac/10mA/1m	No breakdown
Isolation resistance	Input – ground	≥10Mohm @500Vdc	
	Output – ground	≥10Mohm @500Vdc	
Leakage current		<3.5A	Vin = 264Vac
LVD		EN60335-1:2002+EN60335-2-29:2002	

Remark: Discrimination A- Function OK under technical requirement range.

Discrimination R- Physical damage or failure of equipment are not allowed, but damage of protection device (fuse) caused by interference signal of outside is allowed, and the whole equipment can work normally after replacement of protection device and reset of running parameter

6. Environmental testing requirements

Parameter	Technical specification	Remark
High temperature ambient operating	+40°C	Features OK
Low temperature ambient operating	-10°C	Features OK
High temperature storage	+70°C	Work normally after recovery under normal temperature for 2 hours
Low temperature storage	-40°C	Work normally after recovery under normal temperature for 2 hours
Random vibration	20Hz to 2000Hz 3Grms 20hours per axis	
Repetitive shock	40g peak 3 orthogonal axes, 3+ and 3- in each axis, 11ms pulse width	
Thermal shock	-35°C to 75°C, <3min transition, 2.5hours dwell, 200cycle	
Drop test	BS EN60068-2-32:1993 TEST ED: free fall appendix B	

7. Mechanical characteristic:

Shell material: ABS

Outline dimension: L*W*H=137×90×51mm

Input socket: meets 3C standard

AC wires: 70cm length

DC wire: 70cm length

Net Weight: 150g

Drawing:

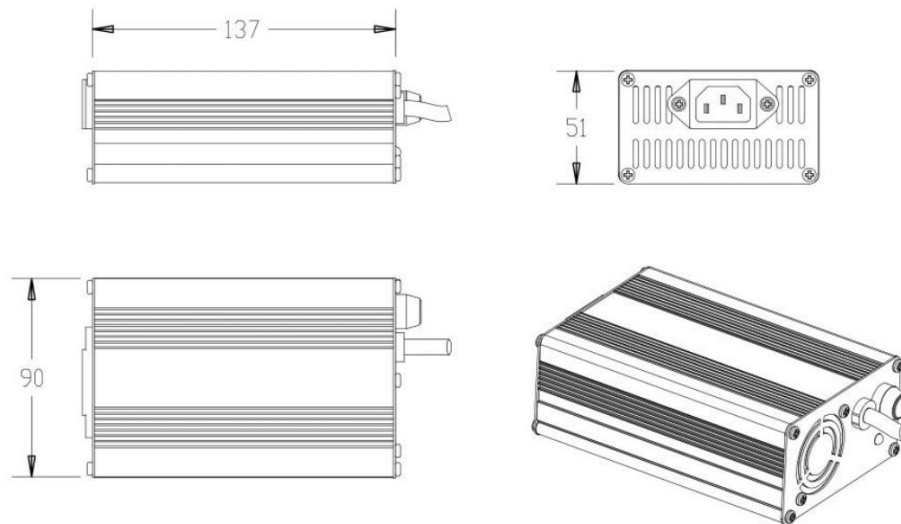

8. Package, transportation & storage

8.1 Package

There is product name, model, name of manufacturer, safety approval, serial number, User manual and packing list in the package box.

8.2 Transportation

Suitable for transportation by truck. The products should be shielded by tent from sunshine and loaded and unloaded carefully.

8.3 Storage

Products should be stored in package box when it is not used. And warehouse temperature should be $-40\sim 70^{\circ}\text{C}$, and relative humidity is $5\sim 95\%$. In the warehouse, there should not be harmful gas, inflammable, explosive products, and corrosive chemical products, and strong mechanical vibration, shock and strong magnetic field affection. The package box should be above ground at least 20cm height, and 50cm away from wall, thermal source, and vent.

Under this requirement, product has 2 years of storage period, and should be rechecked when over 2 years.

9. Reliability requirements

MTBF (standard, environmental temperature, load requirement) $\geq 50\text{K}$ hours.

testing condition: 25°C , full load, testing proved value.

10. Charging curve

